

— *Scott-Greer Sales, Inc.* —

DISTRIBUTORS & MANUFACTURERS REP.

— *Data Sheet* —

OIL & Gas Pump Series O

Chemical Metering
Pumps for the oil
and gas industry.

***Digitally
Accurate
Speed
Adjustment***

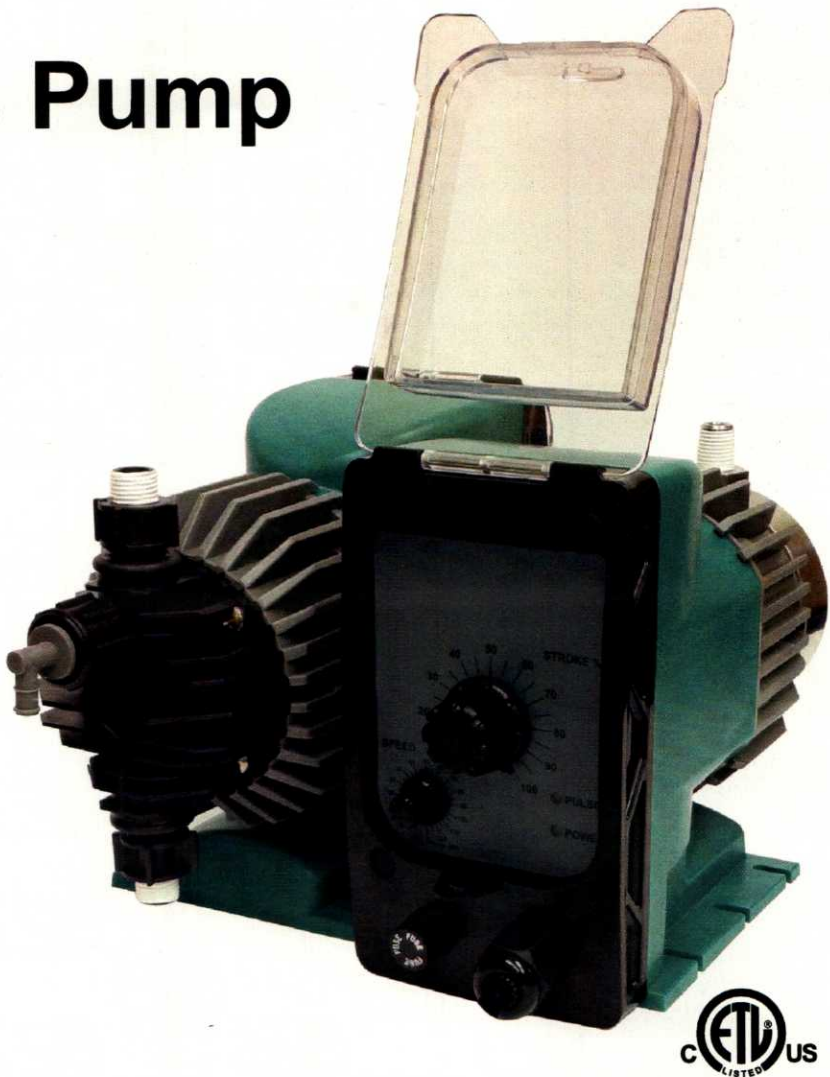

Key Features

- NEMA 4X Style Enclosure
- Guided Double Ball Checks
- Circuit Voltage Protection
- Thermal Overload Protection
- LED Indicating Lights
- Splash Cover Over Controls
- 2 Year Warranty

Application

Series O metering pumps provide reliable, economical chemical addition for a wide variety of applications.

Precise stroking speed is maintained with a digitally accurate speed adjustment. Metering accuracy is achieved with double ball guided checks. A NEMA 4X style housing allows for outdoor installations.

Series O pumps are capable of 17 GPD @ 250 PSI. The digital speed adjustment provides a wide turn down capability on all models.

Scott-Greer Sales, Inc.

DISTRIBUTORS & MANUFACTURERS REP.

Build a Model

Model O _____ - _____

Build your model number by selecting one code from each step. Example: O215X1-KFS1

STEP 1 OUTPUT (MAXIMUM)

- 115 = 15 GPD / 2.37 LPH at 150 PSI (10.3 bar)
- 130 = 30 GPD / 4.70 LPH at 110 PSI (7.5 bar)
- 217 = 17 GPD / 2.60 LPH at 250 PSI (17.2 bar)

STEP 2 CONTROL OPTIONS

- X = Standard

STEP 3 VOLTAGE

- 1 = 120 Volt USA Plug
- 2 = 240 Volt

STEP 4 HEAD MATERIAL

- K = Kynar
- S = Stainless

STEP 5 SEAT MATERIAL

- F = Teflon

STEP 6 CHECK BALL

- S = Stainless

STEP 7 CONNECTIONS

- 1 = 3/8" (9.525 mm) Tubing - 110 & 150 PSI
- 2 = 1/4" (6.35 mm) Tubing - 250 PSI
- 3 = 3/8" (9.525 mm) Tubing - 250 PSI
- P = 1/4" (6.35 mm) MNPT Connections
- Q = 1/4" MNPT discharge & 1/4" FNPT suction
- R = 1/4" (6.35 mm) FNPT Connections

Accessories

3FV-KFS1
Anti-siphon injector
3/8" tubing

3FV-KFSR
Anti-siphon injector
1/4" FNPT



Specifications

Electrical

- Input - 120 VAC or 240 VAC @ 50/60 Hz

Operational

- Stroke length adjustment - 10-100%
- Stroke frequency - 1-125 strokes/minute for 15, 30 & 10 GPD

Enclosure

Heavy duty NEMA 4X style high impact thermoplastic with clear lexan cover.

Environment

- Ambient temperature 32° to 140°F (0 to 60°C)
- Relative humidity 0 to 100%

Shipping Weight: Approximately 10 lbs. (4.536 kg)

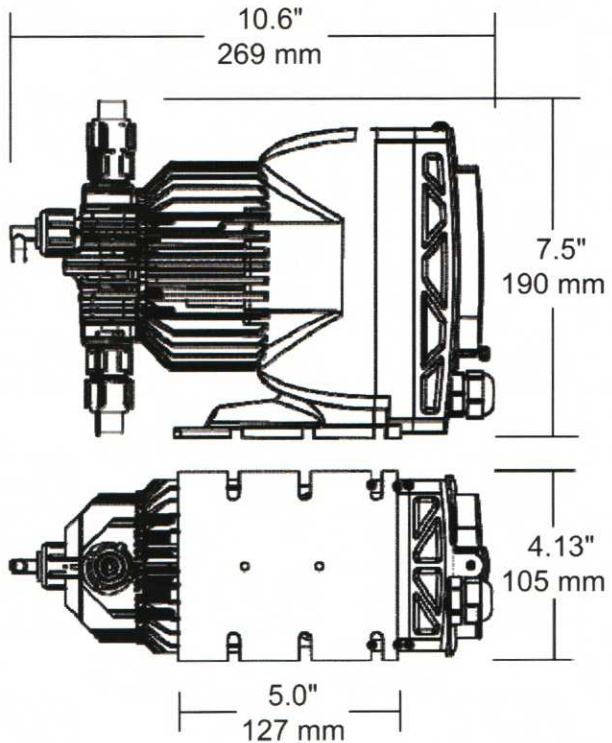

Kynar Head Shown

For other options, see Price List or consult factory.

Scott-Greer Sales, Inc.

DISTRIBUTORS & MANUFACTURERS REP.